

# **Enable Networks UFB Services Agreement Service Description for ATA Voice**

Version 1.1 September 2023

## 1 Interpretation

- 1.1 The ATA Voice Service described in this Service Description will be available from the date it is launched by the LFC. The LFC will notify the Service Provider of the launch date for the ATA Voice Service.
- 1.2 References to clauses or sections are references to clauses or sections in this Service Description unless expressly provided otherwise. The definitions set out in the General Terms and the Operations Manual apply to this Service Description unless expressly provided otherwise.
- 1.3 References to the Operations Manual are references to the Operations Manual for the Bitstream Services.

## 2 The ATA Voice Service

- 2.1 The ATA Voice Service provides the ability for End Users to continue to their existing analogue telephones and telephony services on a GPON-based Bitstream access. The ATA Voice Service is part of the family of Bitstream Services set out below:

Bitstream 2a	Based on the TCF Mass Market service.
Bitstream 3	Based on the TCF Business service.
Bitstream 3a and 3b	Based on the TCF Business service with Low Priority options.
Bitstream 4	Based on the TCF Business Premium service.
Hyperfibre 2 & 3	Based on the LFC Hyperfibre Service Description
UFB Handover Connection	Based on the TCF E-NNI specification.
Multicast	Based on the TCF Ethernet Multicast Access ( <b>EMA</b> ) service.
ATA Voice	An analogue telephone access service.

- 2.2 A diagram of the configuration for the ATA Voice Service is set out in Appendix A. The ATA (Analogue Telephone Adaptor) Voice Service converts an analogue PSTN-compatible 2-wire voice band call into a Bitstream Service that can be delivered to a Service Provider as bitstream.
- 2.3 The ATA Voice Service provides a voice band access service from an End User Premises to a Handover Point that enables a Service Provider access to, and interconnection with, the LFC Network.
- 2.4 The ATA Voice Service is an input service which a Service Provider can combine with other Bitstream Services (and the Service Provider's own network or wholesale services provided by other providers) to provide fibre based voice service to End Users.
- 2.5 The ATA Voice Service has the following key characteristics:
- 2.5.1 Supports PSTN-compatible analogue telephones connected to an ATA Port on the ONT.
  - 2.5.2 Uses a carrier-grade G.711a/G.711u Voice Codec with a 2packetization rate of 10ms.
  - 2.5.3 Supports SIP signalling and H.248 is available if requested using the Product Development Process.
  - 2.5.4 Delivered as a Bitstream Service per port to a UFB Handover Connection Service located at a POI.
  - 2.5.5 Supports New Zealand PSTN tones and cadences as set out in Telecom Network Advisory Specification TNA 102.

### 3 ATA Voice Service and implementation activities

#### **Installation Services**

- 3.1 The ATA Voice Service is delivered from an ATA port on an ONT. The ATA port will be made available during the installation of a stand alone Baseband Service or a Baseband Service as part of a Bitstream 2a, Bitstream 3 or Bitstream 3a Service (each of which includes a Standard Install as set out in their respective Service Descriptions). For the avoidance of doubt, a Standard Install for any Bitstream Service (which includes an ATA Voice Service) does not include the connection of ATA Voice into the Premises wiring.

#### **Core ATA Voice Service**

- 3.2 The ATA Voice Service provides the following key service attributes:
- 3.2.1 An ATA interface on the ONT at the End User site.
  - 3.2.2 Delivered at the Handover Point as G.711a/G.711ubistream with SIP signalling over a single 802.1ad SVLAN on the ENNI. Will also support Cisco QnQ compatible Ethertype.
  - 3.2.3 An Ethernet bitstream service to pass voice traffic between the UNI and E-NNI.
  - 3.2.4 ATA Voice traffic will be treated as High Priority.
  - 3.2.5 Supports the voice standards set out in clause 9.2 of the General Terms.
- 3.3 The ATA Voice Service supports:
- 3.3.1 Analogue voice;
  - 3.3.2 Facsimile; and
  - 3.3.3 A minimum of 14.4 kbps modem transmission,
- however, while the ATA Voice Service supports the above services, it may not be backwards compatible with all existing facsimiles, and modems and customer premises equipment (**CPE**).
- 3.4 E-NNI Characteristics:
- 3.4.1 Voice will be delivered as a unique 802.1ad (or QnQ) VLAN per UNI at the UFB Handover Connection Service.
  - 3.4.2 Traffic will be tagged as 5.
  - 3.4.3 Any traffic received on this VLAN with tags 0, 1, 2, 3, 4, 6 or 7 will be discarded.
  - 3.4.4 CIR will be designed to meet codec and signalling requirements.
  - 3.4.5 The sum of High Priority traffic profiles of all services delivered at a UFB Handover Connection Service can exceed the UFB Handover Connection line rate. If there is insufficient line rate to deliver the High Priority traffic then frames will be randomly discarded and Service Levels will not apply. This may affect call quality.
- 3.5 The ATA Voice Service is a building block service and can only be used in conjunction with Baseband (including with any other Bitstream Service that includes Baseband). ATA Voice and Baseband bundles are as follows:
- 3.5.1 Baseband which includes one ATA Voice Service.
  - 3.5.2 Bitstream 2a, Bitstream 3 or Bitstream 3a packaged with Baseband.
  - 3.5.3 The Service Provider may choose not to activate the ATA Voice Service that is included with Baseband or a Bitstream Service. If the ATA Voice is not activated then it will not appear as a VLAN on a UFB Handover Connection.

- 3.5.4 A second instance of the ATA Voice Service is available on the Baseband Service (or any other Bitstream Service that includes Baseband) as an incremental service or packaged with other services using the Product Development Process.
- 3.6 The ATA Voice Service may require tight coupling with Service Provider voice platforms and thus require customisation and integration testing. The creation and modification of ATA Voice templates or feature sets will be managed through the Product Development Process and implemented using the Service Provider on-boarding process as follows:
  - 3.6.1 Development of appropriate feature templates;
  - 3.6.2 Testing and certification of the ATA Voice Service with Service Provider equipment; and
  - 3.6.3 Deployment and operational integration of the ATA Voice Service with the Service Provider systems and processes.

*Operations, Administration and Maintenance*

- 3.7 The ATA Voice Service will support Service Provider remote access to the ONT via a service management gateway for appropriate management. A Service Provider may request particular management attributes via the Product Development Process.
- 3.8 The ATA Voice Service will support Ethernet Service Operations and Maintenance (**OAM**) for service integrity testing, fault diagnostics and performance measurement using ITU Y.1731. OAM capability will be phased in as the functionality is developed and deployed in scale and may be updated or amended by the LFC from time to time.

*Service Requirements*

- 3.9 To use the ATA Voice Service the Service Provider must have the capability to access and interconnect with it, by one of the following:
  - 3.9.1 Co-locating Service Provider Equipment at the POI using the UFB Handover Connection Service and Central Office and POI Co-location Service;
  - 3.9.2 Connecting to Third Party co-location space at the POI using the UFB Handover Connection Service, and with the third party taking the Central Office and POI Co-location Service;
  - 3.9.3 Connecting to a backhaul service at the POI; or
  - 3.9.4 By using the Direct Fibre Access Service to connect to Service Provider equipment at a remote location within the Central Office area.

*Additional Service Characteristics*

- 3.10 The technical specification of the ATA Voice Service is set out in Appendix B.
- 3.11 The ATA Voice Service includes the following implementation activities carried out by the LFC:
  - 3.11.1 Provisioning and installation of the ATA Voice Service to the extent that this is the responsibility of the LFC under the operational procedures described in the Operations Manual; and
  - 3.11.2 Cable termination and installation of ONT at the End User premises.
- 3.12 The ATA Voice Service specifically excludes:
  - 3.12.1 The UFB Handover Connection Service;
  - 3.12.2 Provision or maintenance of any cabling or connection or active device beyond the service demarcation points described in clauses 4.1 and 5.1;
  - 3.12.3 Configuration, monitoring, operation, on-going support or maintenance of Service Providers' or End User applications, equipment or networks;
  - 3.12.4 Configuration or on-going support of End User applications; and

- 3.12.5 Supply of AC Mains & UPS Power, accommodation space, heating, ventilating, and air conditioning and other similar services and facilities at the POI or End User Premises.

#### **4 End User Service Demarcation Point**

- 4.1 The ATA Voice Service is delivered to an ATA port on the ONT at the End User Premises.
- 4.2 The ATA Voice Service excludes the End User Premises wiring. If a fault reported by the Service Provider is found to be caused by the End User Premises equipment (CPE) or the wiring at the End User's Premises beyond the service demarcation point, then the Service Provider may be charged the no fault found fee in the Price List. Note the wiring should comply with the industry standard Premises wiring requirements which are available at [www.tcf.org.nz](http://www.tcf.org.nz).

#### **5 LFC Service Demarcation Point**

- 5.1 The ATA Voice Service is delivered as a VLAN on the UFB Handover Connection Service located in the POI.
- 5.2 The UFB Handover Connection Service is a separate service and is a prerequisite to purchasing the ATA Voice Service.

#### **6 LFC and Service Provider Responsibilities**

- 6.1 Other LFC and Service Provider responsibilities are detailed in the General Terms and the Operations Manual.

## Appendix A – Diagram

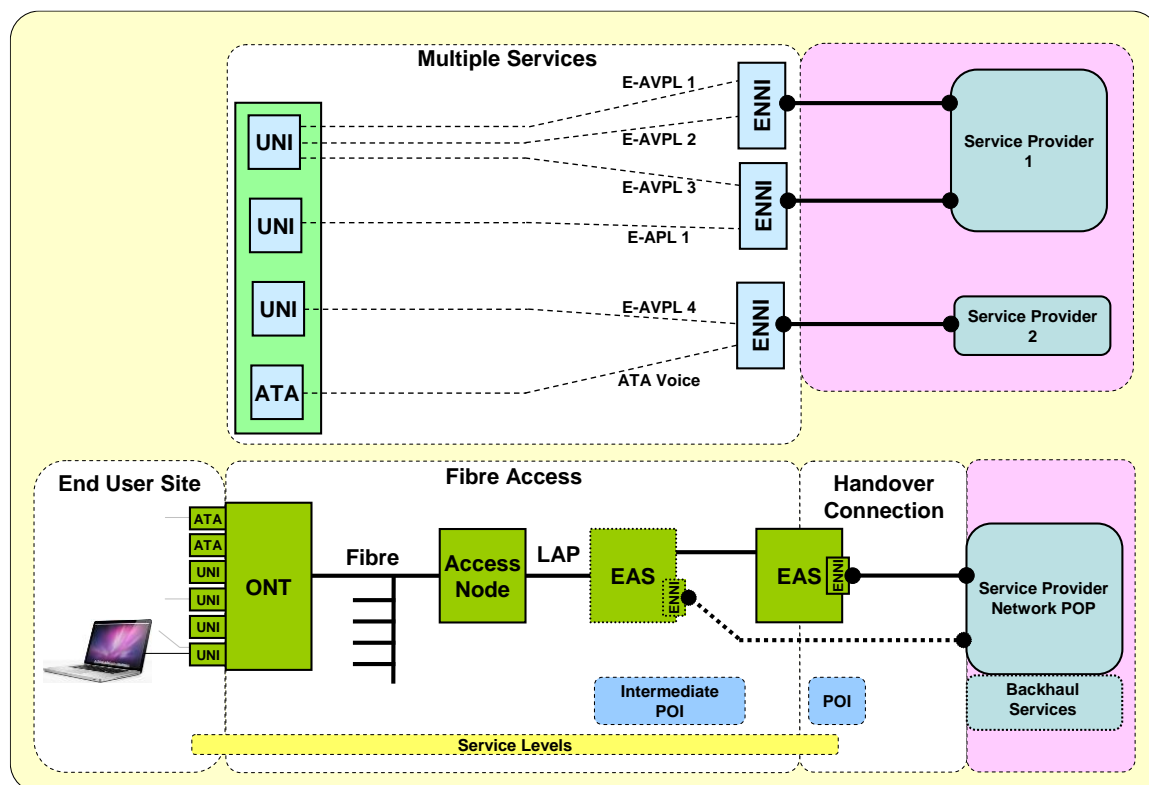

This is a generic diagram showing the standard configuration and service demarcation points. It is not intended to represent every situation or detailed physical architecture. The following points should be noted:

- The ATA Voice Service and pricing applies from the UNI to the E-NNI at the POI, i.e. there is no incremental charge from the Intermediate POI to the POI.
- Some Bitstream Services will have a single tier of aggregation, i.e. there is no Intermediate POI.
- Where there are multiple tiers of aggregation, the Service Provider can pick the service up at an Intermediate POI. This intermediate POI will service a limited coverage area.
- Service Levels (availability, network performance) only apply between the ATA port and the ENNI at the POI.
- Access node and aggregation interconnection may use redundant links to meet Service Level requirements.

The Bitstream services support simultaneous delivery of multiple Service Templates from the same or multiple service providers as follows:

- Multiple A-EVPLs can be delivered to the same UNI.
- An A-EPL service requires a dedicated UNI.
- An ATA Voice service can be considered an A-EVPL with an ATA Port at the End User interface. The class and bandwidth characteristics of this A-EVPL are optimised for voice.
- All services delivered to a UNI must belong to the same Service Provider but can be mapped to the same or different E-NNIs.

## Appendix B – Technical Specification

### Technical Specification

ATA Voice Port	RJ11 Analogue interface compliant with PTC 220, section 5.
UFB Handover Connection (E-NNI)	Ethernet: <ul style="list-style-type: none"><li>• 802.1ad VLAN (SVID, CVID); or</li><li>• Double tagged QnQ.</li><li>• PCP = 5.</li><li>• Untagged or PCP = 0, 1, 2, 3, 4, 6 or 7 discarded.</li></ul>
Line and information signalling	DTMF dialling. Ringing cadences as specified in Telecom Network Advisory Specification TNA 102. FSK signalling. Dial tone spec, incl stutter dial tone for MWI.
Codec	G.711a/G.711u codec at 10ms sampling rate. 200 byte packet metric. Maximum delay allowance for jitter of 20ms. Other codecs can be considered and implemented using the Product Development Process.
Voice band data support	DTMF in band and RFC 2833. Transmission characteristics capable of supporting minimum 14.4kb/s voice band data transmission for fax and modems.
SIP	RFC 3261 SIP: Session Initiation Protocol, June 2002.