



Enable Networks UFB Services Agreement  
Service Description for Bitstream 3b

## 1 Interpretation

- 1.1 The Bitstream 3b Service described in this Service Description will be available from the date it is launched by the LFC. The LFC will notify the Service Provider of the launch date for the Bitstream 3b Service.
- 1.2 References to clauses or sections are references to clauses or sections in this Service Description unless expressly provided otherwise. The definitions set out in the General Terms and the Operations Manual apply to this Service Description unless expressly provided otherwise.
- 1.3 References to the Operations Manual are references to the operations manual for the Bitstream Services.

## 2 The Bitstream 3b Service

- 2.1 The Bitstream 3b Service is a multi-class Bitstream Service suitable for complex business grade applications and premium residential products delivered over a shared fibre access. Bitstream 3b is part of the UFB family of Bitstream Services:

Bitstream 2 and 2a	Based on the TCF Mass Market service.
Bitstream 3	Based on the TCF Business service.
Bitstream 3a and 3b	Based on the TCF Business service with Low Priority options.
Bitstream 4	Based on the TCF Business Premium service.
UFB Handover Connection	Based on the TCF E-NNI specification.
Multicast	Based on the TCF Ethernet Multicast Access ( <b>EMA</b> ) service.
ATA Voice	An analogue telephone access service.

- 2.2 A diagram of the configuration for the Bitstream 3b Service is set out in Appendix A. The Bitstream 3b Service provides an Ethernet E-APL Bitstream Service from the UNI at the End User Premises (or End User Tenancy in the case of an MDU) to the UFB Handover Connection Service located at the POI that enables a Service Provider to access and interconnect with the LFC Network.
- 2.3 The Bitstream 3b Service is an input service which a Service Provider can combine with other LFC services (or with the Service Provider's own network or wholesale services provided by other service providers) to provide fibre based telecommunications services to End Users.
- 2.4 The Bitstream 3b Service has the following key characteristics:
- 2.4.1 The Bitstream 3b Service includes an Ethernet Bitstream Service that allows up to 4050 VLANs to be passed transparently from the End User Premises to the Service Provider, delivered over GPON (shared) fibre.
  - 2.4.2 Support for two classes of traffic, High Priority and Low Priority.
  - 2.4.3 A range of Service Template package offers. A single Service Template is initially offered consisting of a single Ethernet E-APL Bitstream with a range of bandwidth options and a single instance of the ATA Voice Service, with the option to create modified or new Service Templates using 'core building blocks' and the Product Development Process.
  - 2.4.4 Supports tagged or untagged traffic by the End User at the UNI.
  - 2.4.5 Complies with the Business service specified in the Telecommunications Carriers Forum's Ethernet Access Service Description v24, 19 January 2011.

### 3 Bitstream 3b Service and implementation activities

#### **Installation Services**

3.1 The Bitstream 3b Service includes a Standard Install as set out below (in each case to the extent that the relevant provisioning works are not already complete for the relevant Service Order).<sup>1</sup>

##### *Provisioning at Single Dwelling Unit End User's Premises*

3.1.1 A Standard Install for the Bitstream 3b Service to a Single Dwelling Unit includes:

- (a) a Fibre Lead-in from the Fibre Access Point to an ETP at the closest convenient point on the End User Premises, as agreed with End User, where the Fibre Lead-in utilises no more than:
  - (i) 100m of approved conduit or open trench (already in place at the time of installation); or
  - (ii) a double span of aerial drop lead on existing poles from the Fibre Access Point (this will include road crossings and is available only in areas where there is overhead deployment); or
  - (iii) 30m of buried lead-in (available only in areas where there is underground deployment); and
- (b) an extension of the Fibre Lead-in up to 10m radius from the ETP (there will not necessarily be a break in the Fibre Lead-in at the ETP) to:
  - (i) a suitable mounted SC/APC connector at a secure location inside the End User Premises; or
  - (ii) if there is an OFDF beyond the ETP, a splice or LCA connector on the OFDF.

3.1.2 The LFC will provide Non-Standard Installs for the Bitstream 3b Service to Single Dwelling Units as an Ancillary Service.

##### *Provisioning at MDU End User's Premises*

3.1.3 A Standard Install for the Bitstream 3b Service to an End User that is within a MDU (i.e. an End User Tenancy) includes:

- (a) a Fibre Lead-in from the Fibre Access Point to the OFDF or equivalent at the closest convenient point within the MDU, as agreed with the MDU owner or their agent, where the Fibre Lead-in utilises no more than:
  - (i) 100m of approved conduit or open trench (already in place at the time of installation); or
  - (ii) a double span of aerial drop lead on existing poles from the Fibre Access Point (this will include road crossings and is available only in areas where there is overhead deployment); or
  - (iii) 30m of buried lead-in (available only in areas where there is underground deployment); and
- (b) where the fibre cabling in a MDU to the End User Tenancy is not already in place at the time of installation of the Bitstream 3b Service, fibre cabling within the MDU to extend the Fibre-Lead-in from the OFDF or equivalent to the End-User Tenancy; and
- (c) either

---

<sup>1</sup> Standard Install parameters may differ between LFCs.

- (i) a further extension of the Fibre Lead-in up to a 10m radius from the ETP at the End User Tenancy (there will not necessarily be a break in the Fibre Lead-in at the ETP) to:
  - (A) a suitable mounted SC/APC connector at a secure location; or
  - (B) if there is an OFDF beyond the ETP, a splice or LCA connector on the OFDF,
    - within the End User Tenancy; or
- (ii) if there is not an ETP at the End User Tenancy as contemplated by clause 3.1.3(c)(i), a further extension of the Fibre Lead-in up to 10m radius from the boundary of the End User Tenancy to:
  - (A) a suitable mounted SC/APC connector at a secure location; or
  - (B) if there is an OFDF beyond the boundary, a splice or LCA connector on the OFDF,
    - within the End User Tenancy.

- 3.1.4 The extended LFC Network fibre within the MDU is the Fibre Lead-in to an End User Tenancy, whether currently in use or not. The Fibre Lead-in is only available for use by the LFC.
- 3.1.5 The LFC will provide Non-Standard Installs for the Fibre Lead-in to End User Tenancies within MDUs as an Ancillary Service.

*Single Dwelling Unit Termination Point*

- 3.1.6 For a Single Dwelling Unit, the termination point of the Layer 1 component of the Bitstream 3b Service for the purposes of the Connection at the End User's Premises, and the network demarcation point between the LFC Network and the Premises wiring is, as applicable, either:
  - (a) the SC/APC connector on the end of the Fibre Lead-in from the ETP (which is the connector); or
  - (b) if there is an OFDF beyond the ETP, a splice or LCA connector on the OFDF,
    - provided that any ONT installed by the LFC as part of the Bitstream 3b Service will also be part of the LFC Network.
- 3.1.7 The termination point of the Layer 2 component of the Bitstream 3b Service is the 100/1000Base-T UNI on the ONT.

*MDU Termination Point*

- 3.1.8 For MDUs the termination point of the Layer 1 component of the Bitstream 3b Service for the purposes of the Connection at the End User's Tenancy, and the network demarcation point is, as applicable, either:
  - (a) the SC/APC connector on the end of the Fibre Lead-in (which is the jack); or
  - (b) if there is an OFDF beyond the ETP or End User Tenancy boundary, a splice or LCA connector on the OFDF,
    - within the End User Tenancy, provided that any ONT installed by the LFC as part of the Bitstream 3b Service will also be part of the LFC Network.
- 3.1.9 The termination point of the Layer 2 component of the Bitstream 3b Service is the 100/1000Base-T UNI on the ONT.

*Alternative Termination Points*

- 3.1.10 The LFC and the Service Provider may agree on a different termination point as part of a Non-Standard Install. This may be necessary where, for example, there is installation to

a NBAP. A Non Standard Install for a Bitstream 3b Service within a Multi Dwelling Unit will not include termination in a building common area or other facility made available by the owner to service the Multi Dwelling Unit, where a Fibre Lead-in has not been extended from the OFDF to the inside of an End User Tenancy.

#### *Installation of ONT*

- 3.1.11 A Standard Install for the Bitstream 3b Service includes installation of an ONT including:
- (a) supply and fixing of the ONT to the structure of the End User Premises (in the case of a Single Dwelling Unit or an End User Tenancy (in the case of an MDU);
  - (b) supply and connection of fibre pigtail up to 1m long between the Fibre Lead-in termination point and the ONT if required; and
  - (c) testing from the UNI port of the ONT to ensure the Bitstream 3b Service is within the technical specification set out in Appendix B.
- 3.1.12 The Service Provider must ensure the End User provides a suitably located mains power outlet for the ONT power supply which is not provided as part of a Standard Installation.
- 3.1.13 The LFC will not provide space and power at any End User Premise for the ONT. These are the responsibility of the End User. The location of the ONT must be a suitable environment for electronic equipment being generally a dry, clean indoor area with adequate ventilation.

#### *Testing*

- 3.2 The LFC will test the Fibre Lead-in from the termination point at the End User's Premises referred to in clause 3.1.6, 3.1.8 or 3.1.10 to the Central Office where the access node is located to ensure the fibre is within the technical specification for fibre set out in Appendix B.

#### *Additional Services*

- 3.3 If the Service Provider requires additional services such as:
- 3.3.1 a Non-Standard Install which includes (where required):
    - (a) an extension of the Fibre Lead-in over the maximum distances specified in clauses 3.1.1 (in relation to Single Dwelling Units) or 3.1.3 (in relation to End User Tenancies within MDUs);
    - (b) installation to a NBAP utilising specialised termination equipment; or
    - (c) installation of Fibre-Lead-in diversity at an End User's Premises (from the FAP to the ETP or OFDF as applicable);
  - 3.3.2 provision of diversity to End User's Premises (when the second or subsequent instance of the Bitstream 3b Service is purchased);
  - 3.3.3 Premises wiring services; or
  - 3.3.4 installation and testing of Service Provider equipment and services,
- then the LFC may be able to provide the services in clauses 3.3.2 to 3.3.4 on request, subject to terms to be agreed between the LFC and the Service Provider. The services in clauses 3.3.1 and 3.3.2 are available on terms as set out in this Agreement.

#### **Core Bitstream 3b Service**

- 3.4 The core Bitstream Services provided as part of the Bitstream 3b Service are as follows:
- 3.4.1 An Ethernet E-APL Service that supports transparent pass-through of 802.1Q frames on a designated UNI on the ONT at the End User Premises.
  - 3.4.2 Delivered over a single 802.1ad SVLAN on the E-NNI at the POI.
  - 3.4.3 Bandwidth overhead for Low Priority to compensate for higher protocol encapsulation overheads. The size of the overhead is calculated as follows:

- (a) 10% overhead for downstream PIR < 200 Mbps, e.g. 165 Mbps for a 150 Mbps headline PIR DS;
- (b) 8.5% overhead for downstream PIR ≥ 200 Mbps e.g. 325.5 Mbps for a 300 Mbps headline PIR DS; and
- (c) 10% overhead for upstream PIR e.g. 110 Mbps for a 100Mbps headline PIR US

This bandwidth overhead does not guarantee End Users will experience the headline speed as their experience is dependent on a number of external factors including, but not limited to, End User applications and local network, the Service Provider network and location of the content they are accessing.

3.4.4 Tagged Traffic is treated as follows:

- (a) Untagged traffic sent from the End User is tagged and treated as Low Priority.
- (b) Traffic tagged with PCP = 0 will be treated as Low Priority.
- (c) Traffic tagged with PCP = 1, 2, 3, 4, 5, 6 or 7 will be treated as High Priority.
- (d) Traffic will be treated as follows based on the individual frames priority:

Type	Ingress	Transport
Low Priority	CIR ≥ 2.5 Mbps. EIR ≥ 0. EIR + CIR policed at ingress.	EIR Queued and Weighted fairly under congestion conditions.
High Priority	CIR ≥ 0. EIR = 0.	Prioritised.

Low Priority traffic can burst up to the Headline Rate.

3.4.5 The following initial Service Templates are available consisting of one ATA Voice service and one Ethernet Bitstream Service, using the following parameters:

- (a) Headline rate (50/50, 200/200, 500/500 or Max/Max);
  - (i) Headline rate 50/50;
  - (ii) Headline rate 200/200;
  - (iii) Headline rate 500/500; and
  - (iv) Headline rate Max/Max.

Where Headline rate is the Layer 2 bandwidth prior to the addition of the overhead described in clause 3.4.3.

Max/Max means that Low priority is set to 1000/1000 Mbps. The maximum throughput of the UNI is 1000 Mbps including Ethernet preamble, frame delimiters and inter-frame gaps. Thus the maximum throughput will be less than the UNI speed and vary according to frame size;

- (b) High Priority service bandwidth; and
- (c) Low Priority service bandwidth,

as set out in the table below, and can be modified or combined with other services using the Product Development Process as described in clause 3.7.

Access Rate	ATA <sup>[1]</sup> ports	Headline <sup>[2]</sup>		Low Priority <sup>[3]</sup> PIR (Mbps)		Low Priority Downstream				Low Priority Upstream				High Priority Downstream				High Priority Upstream			
		Low Priority (Mbps) DS/US	High Priority (Mbps) DS/US	Down	Up	EIR	EBS	CIR	CBS	EIR	EBS	CIR	CBS	EIR	EBS	CIR	CBS	EIR	EBS	CIR	CBS
						[6]	[4]		[4]	[6]	[4]		[4]		[4]		[4]		[4]		[4]
Mbps	kB	Mbps	kB	Mbps	kB	Mbps	kB	Mbps	kB	Mbps	kB	Mbps	kB	Mbps	kB	Mbps	kB	Mbps	kB	Mbps	kB
50/50	1	50/50	2.5/2.5	55	55	52.5	130	2.5	32	52.5	130	2.5	32	0	0	2.5	32	0	0	2.5	32
			10/10			52.5	130	2.5	32	52.5	130	2.5	32	0	0	10	32	0	0	10	32
			20/20			52.5	130	2.5	32	52.5	130	2.5	32	0	0	20	32	0	0	20	32
			30/30			52.5	130	2.5	32	52.5	130	2.5	32	0	0	30	32	0	0	30	32
			40/40			52.5	130	2.5	32	52.5	130	2.5	32	0	0	40	32	0	0	40	32
			50/50			52.5	130	2.5	32	52.5	130	2.5	32	0	0	50	32	0	0	50	32
200/200	1	200/200	2.5/2.5	217	220	214.5	180	2.5	32	217.5	180	2.5	32	0	0	2.5	32	0	0	2.5	32
			10/10			214.5	180	2.5	32	217.5	180	2.5	32	0	0	10	32	0	0	10	32
			20/20			214.5	180	2.5	32	217.5	180	2.5	32	0	0	20	32	0	0	20	32
			30/30			214.5	180	2.5	32	217.5	180	2.5	32	0	0	30	32	0	0	30	32
			40/40			214.5	180	2.5	32	217.5	180	2.5	32	0	0	40	32	0	0	40	32
			50/50			214.5	180	2.5	32	217.5	180	2.5	32	0	0	50	32	0	0	50	32
			60/60			214.5	180	2.5	32	217.5	180	2.5	32	0	0	60	38	0	0	60	38
			70/70			214.5	180	2.5	32	217.5	180	2.5	32	0	0	70	44	0	0	70	44
			80/80			214.5	180	2.5	32	217.5	180	2.5	32	0	0	80	50	0	0	80	50
			90/90			214.5	180	2.5	32	217.5	180	2.5	32	0	0	90	57	0	0	90	57
100/100	214.5	180	2.5	32	217.5	180	2.5	32	0	0	100	63	0	0	100	63					
500/500	1	500/500	2.5/2.5	542.5	550	540	180	2.5	32	547.5	180	2.5	32	0	0	2.5	32	0	0	2.5	32
			10/10			540	180	2.5	32	547.5	180	2.5	32	0	0	10	32	0	0	10	32
			20/20			540	180	2.5	32	547.5	180	2.5	32	0	0	20	32	0	0	20	32
			30/30			540	180	2.5	32	547.5	180	2.5	32	0	0	30	32	0	0	30	32

				40/40			540	180	2.5	32	547.5	180	2.5	32	0	0	40	32	0	0	40	32
				50/50			540	180	2.5	32	547.5	180	2.5	32	0	0	50	32	0	0	50	32
				60/60			540	180	2.5	32	547.5	180	2.5	32	0	0	60	38	0	0	60	38
				70/70			540	180	2.5	32	547.5	180	2.5	32	0	0	70	44	0	0	70	44
				80/80			540	180	2.5	32	547.5	180	2.5	32	0	0	80	50	0	0	80	50
				90/90			540	180	2.5	32	547.5	180	2.5	32	0	0	90	57	0	0	90	57
				100/100			540	180	2.5	32	547.5	180	2.5	32	0	0	100	63	0	0	100	63
Max/Max [5]	1		Max/Max [5]	2.5/2.5	1000	1000	997.5	250	2.5	32	997.5	250	2.5	32	0	0	2.5	32	0	0	2.5	32
				10/10			997.5	250	2.5	32	997.5	250	2.5	32	0	0	10	32	0	0	10	32
				20/20			997.5	250	2.5	32	997.5	250	2.5	32	0	0	20	32	0	0	20	32
				30/30			997.5	250	2.5	32	997.5	250	2.5	32	0	0	30	32	0	0	30	32
				40/40			997.5	250	2.5	32	997.5	250	2.5	32	0	0	40	32	0	0	40	32
				50/50			997.5	250	2.5	32	997.5	250	2.5	32	0	0	50	32	0	0	50	32
				60/60			997.5	250	2.5	32	997.5	250	2.5	32	0	0	60	38	0	0	60	38
				70/70			997.5	250	2.5	32	997.5	250	2.5	32	0	0	70	44	0	0	70	44
				80/80			997.5	250	2.5	32	997.5	250	2.5	32	0	0	80	50	0	0	80	50
				90/90			997.5	250	2.5	32	997.5	250	2.5	32	0	0	90	57	0	0	90	57
				100/100			997.5	250	2.5	32	997.5	250	2.5	32	0	0	100	63	0	0	100	63

[1] The ATA service is as described in the ATA Voice Service Description except that the High Priority frames are tagged with PCP 5.

[2] The headline rate is the Layer 2 bandwidth prior to the addition of the overhead described in section 3.4.3

[3] Low Priority 'Peak Information Rate', which is the headline rate plus the bandwidth overhead described in clause 3.4.3, is the sum Low Priority EIR and Low Priority CIR.

[4] This is the minimum specification.

[5] Max that Low priority Downstream is set to 1000 Mbps. The maximum throughput of the UNI is 1000 Mbps including Ethernet preamble, frame delimiters and inter-frame gaps. Thus the maximum throughput will be less than the UNI speed and vary according to frame size.

[6] These values are the layer 2 bandwidths and include the additional overhead compensation described in section 3.4.2.



3.4.6 The Bitstream 3b Service has similar characteristics to the other services within the UFB family of Bitstream Services as identified below:

Attribute	Bitstream 2 Bitstream 2a	Bitstream 3	Bitstream 3a Bitstream 3b	Bitstream 4
Bitstream	E-AVPL	E-APL	E-APL	E-APL
High Priority	Yes	Yes	Yes	Yes
Low Priority	Yes	No	Yes	No
Service Bandwidths (Reference Offer)*	Low Priority from 30/10 Mbps up to 100/50 Mbps  Low Priority + High Priority up to 110/52.5 Mbps	From 2.5Mbps up and downstream to 100/100 Mbps	High Priority from 2.5/2.5 Mbps to 90/90 Mbps  Low Priority + High Priority = 100/100 Mbps	From 100 Mbps up to 10 GigE
Service Bandwidths (2a and 3b)*	Low Priority from 30/10 Mbps up to 200/200 Mbps  Low Priority + High Priority CIR up to 100/50 Mbps		Low Priority from 50/50 Mbps up to 1000/1000 Mbps with High Priority from 2.5/2.5 Mbps up to 100/100 Mbps	
MTU	2000 Bytes	2000 Bytes	2000 Bytes	9100
MAC addresses	16	64	64	128
Number of available UNIs	4 standard	4 standard	4 standard	1 with a second UNI available on request
L2CP support	No	No	No	Limited
Diversity	On request with limited availability	On request with limited availability	On request with limited availability	Available to Priority Users in selected areas

\* Bandwidth options for each Bitstream Service are detailed in each Bitstream Service Description and further options can be developed using the Product Development Process.

3.4.7 The standard ONT for the Bitstream 3b Service supports a maximum of three 100Ethernet UNIs and two ATA Voice ports. Additional configurations are available on request.

*UNI – NNI characteristics*

3.4.8 The Bitstream 3b Service requires a dedicated UNI. Additional UNIs can be used for additional instances of the Bitstream 3 or 3a Service or Bitstream 3b Service.

3.4.9 The sum of High and Low Priority traffic profiles of all services delivered at a UFB Handover Connection Service can exceed the UFB Handover Connection Service line rate. If there is insufficient line rate to deliver the traffic then frames will be randomly

discarded, based on their Class of Service precedence, and Service Levels for that Class of Service do not apply. It is therefore the Service Provider's responsibility to shape and queue traffic appropriately.

#### *New Service Template Options*

- 3.5 A Service Provider may request that the LFC creates additional Service Templates as follows:
- 3.5.1 Additional Service Templates can be created using combinations of one more of the following set of standard building blocks:
- (a) Point to Point VLAN (E-APL) service using High Priority and Low Priority combinations as set out in this Service Description and clause 2.5.2 below
  - (b) Multicast VLAN Ethernet Bitstream Service (EMA) using High Priority (CIR) only;
  - (c) ATA Voice port;
  - (d) UNI (100/1000 Base-T) port;
  - (e) WiFi; and
  - (f) Other services or attributes requested by the Service Provider and agreed by the LFC.
- 3.5.2 Ethernet Bitstream Services consisting of High Priority and Low Priority traffic combinations can be created using the following standard building blocks:
- (a) High Priority in increments of 2.5 Mbps upstream and/or downstream;
  - (b) Headline Rate in increments of 10 Mbps upstream and/or downstream; and
- 3.5.3 Low Priority CIR in increments of 2.5 Mbps upstream and/or downstream.
- 3.6 Service Templates can be added incrementally to an existing service offer, or supplied as a stand-alone package.
- 3.6.1 Stand alone packages must include Baseband. Stand alone packages mean that the End User connection does not need to consume any other Service Templates in order for services to be provided.
- 3.6.2 Incremental packages can be added as an additional service to an End User who is already consuming one or more Service Templates.
- 3.6.3 Baseband is a required service for all End User connections. If the Service Template that includes Baseband is removed from an End User connection and an incremental Service Template remains, then Baseband will be added to the incremental Service Template for that End User.
- 3.7 Requests for additional Service Templates will be implemented and delivered through the Product Development Process. The Product Development Process includes determination of pricing, development, testing and implementation.
- 3.8 The LFC will comply with the Service Provider's request under clause 3.5 in a timely manner. In the event that demand for new Service Templates exceeds the LFC's capacity to deliver the new Service Templates then the LFC may prioritise the Service Template requests in accordance with the Operations Manual.

#### *Operations, Administration and Maintenance*

- 3.9 The Bitstream 3b Service may in the future support Service Provider remote access to the ONT via a service management gateway for appropriate management. A Service Provider may request particular management attributes via the Product Development Process.
- 3.10 The Bitstream 3b Service may in the future support Ethernet Service Operations and Maintenance (**OAM**) for service integrity testing, fault diagnostics and performance measurement using ITU Y.1731. OAM capability will be phased in as the functionality is developed and deployed in scale and may be updated or amended by the LFC from time to time.

### *Service Requirements*

- 3.11 To use the Bitstream 3b Service the Service Provider must have the capability to access and interconnect with it, by one of the following:
- 3.11.1 Co-locating Service Provider equipment at the POI using the UFB Handover Connection Service and Central Office and POI Co-location Service;
  - 3.11.2 Connecting to third party co-location space at the POI using the UFB Handover Connection Service, and with the third party taking the Central Office and POI Co-location Service;
  - 3.11.3 Connecting to a backhaul service at the POI; or
  - 3.11.4 By using the Direct Fibre Access Service to connect to Service Provider equipment at a remote location within the Central Office area.

### *Additional Service Characteristics*

- 3.12 The technical specification of the Bitstream 3b Service is set out in Appendix B.
- 3.13 The LFC will provide certain support and other assistance as part of the Bitstream 3b Service including:
- 3.13.1 An electronic facility for Service Requests;
  - 3.13.2 An electronic facility for fault notifications; and
  - 3.13.3 A tool to assist the Service Provider in determining the location and availability of the Bitstream 3b Service (pre-qualification),
- each as more particularly set out in the Operations Manual.
- 3.14 The Bitstream 3b Service specifically excludes:
- 3.14.1 The UFB Handover Connection Service;
  - 3.14.2 Provision or maintenance of any cabling or connection or active device:
    - (a) beyond the service demarcation points described in clauses 4.1 and clause 5.1;
    - (b) between the jack terminating the LFC provided Fibre Lead-in and the ONT where that cabling or connection is not provided by the LFC and the LFC has not agreed to take responsibility for that cabling or connection.
  - 3.14.3 Configuration, monitoring, operation, on-going support or maintenance of Service Providers' or End Users' applications, equipment or networks; and
  - 3.14.4 Supply of AC mains & UPS power, accommodation space, heating, ventilating, and air conditioning and facilities at the End User Premises.

### *Provisioning at an NBAP*

- 3.15 A Standard Install for the Bitstream 3b Service to an NBAP includes:
- 3.15.1 A Fibre Lead-in from the Fibre Access Point to an ETP at the closest convenient point on the NBAP, as agreed with End User, where the Fibre Lead-in utilises no more than:
    - (a) 100m of approved conduit or open trench (already in place at the time of installation); or
    - (b) a double span of aerial drop lead on existing poles from the Fibre Access Point (this will include road crossings and is available only in areas where there is overhead deployment); or
    - (c) 30m of buried lead-in (available only in areas where there is underground deployment); and
  - 3.15.2 An extension of the Fibre Lead-in up to 10m radius from the ETP (there will not necessarily be a break in the Fibre Lead-in at the ETP) to:

- (a) a suitable mounted SC/APC<sup>2</sup> connector at a secure location inside the NBAP;  
or
  - (b) if there is an OFDF beyond the ETP, a splice or LCA connector on the OFDF.
- 3.15.3 The LFC will provide Non-Standard Installs for the Bitstream 3b Service to an NBAP as an Ancillary Service.

#### **4 Service Demarcation Point at End User Premises**

- 4.1 The service demarcation point at the End User's Premises is the 100/1000Base-T UNI on the ONT.
- 4.2 The Bitstream 3b Service excludes the End User Premises wiring. If a fault reported by the Service Provider is found to be caused by the End User Premises equipment (CPE) or the wiring at the End User's Premises beyond the service demarcation point, then the Service Provider may be charged the no fault found fee in the Price List. Note the wiring should comply with the industry standard Premises wiring requirements which are available at [www.tcf.org.nz](http://www.tcf.org.nz).

#### **5 Service Demarcation Point at POI**

- 5.1 The Bitstream 3b Service is delivered as a transparent VLAN (the logical service demarcation point) on the UFB Handover Connection located at the POI.
- 5.2 The physical service demarcation point is the MOFDF in the POI, which is part of the UFB Handover Connection Service.
- 5.3 The UFB Handover Connection Service is a separate service and is a prerequisite to the supply of the Bitstream 3b Service i.e. Service Provider's must first purchase and then continue to maintain a UFB Handover Connection Service at all times while taking the Bitstream 3b Service.

#### **6 LFC and Service Provider Responsibilities**

- 6.1 Other LFC and Service Provider responsibilities are detailed in the General Terms and the Operations Manual.

#### **7 Fibre Diversity**

- 7.1 The Bitstream 3b Service provides a single fibre between the Central Office and the End User's Premises.
- 7.2 Diversity (a second or subsequent instance of the Bitstream 3b Service between the Fibre Access Point and the Central Office) will be available as an option for some but not all Premises. Standard Installation Service Levels do not apply to the provision of the diverse products and each instance will be treated as an individual line for the purpose of availability Service Levels.
- 7.3 Where available, the diverse optical paths will be in separate fibre cable sheaths, and if requested in separate cable routes. The diverse cable routes will be a minimum of the width of a street apart, and should not share any manholes or access points. Separate entries into the Central Office will also be used where available.
- 7.4 The Service Provider can also request diverse access to End User Premises, or access to diverse Central Offices as part of a Non-Standard Install, however this will not be available in all cases.
- 7.5 There may be practical limitations to providing full physical diversity to some sites. The provision of a separate entry to an LFC Central Office will have unique site specific engineering considerations and may attract additional costs.

---

<sup>2</sup> SC/APC – Standard Connector/Angle Polished Connector to IEC 61754-4.

## **8 Bitstream 3b Service Levels**

- 8.1** Service Levels for both the Layer 1 and Layer 2 components of the Bitstream 3b Service are set out in the Service Level Terms for the Bitstream Services.

## Appendix A – Diagram

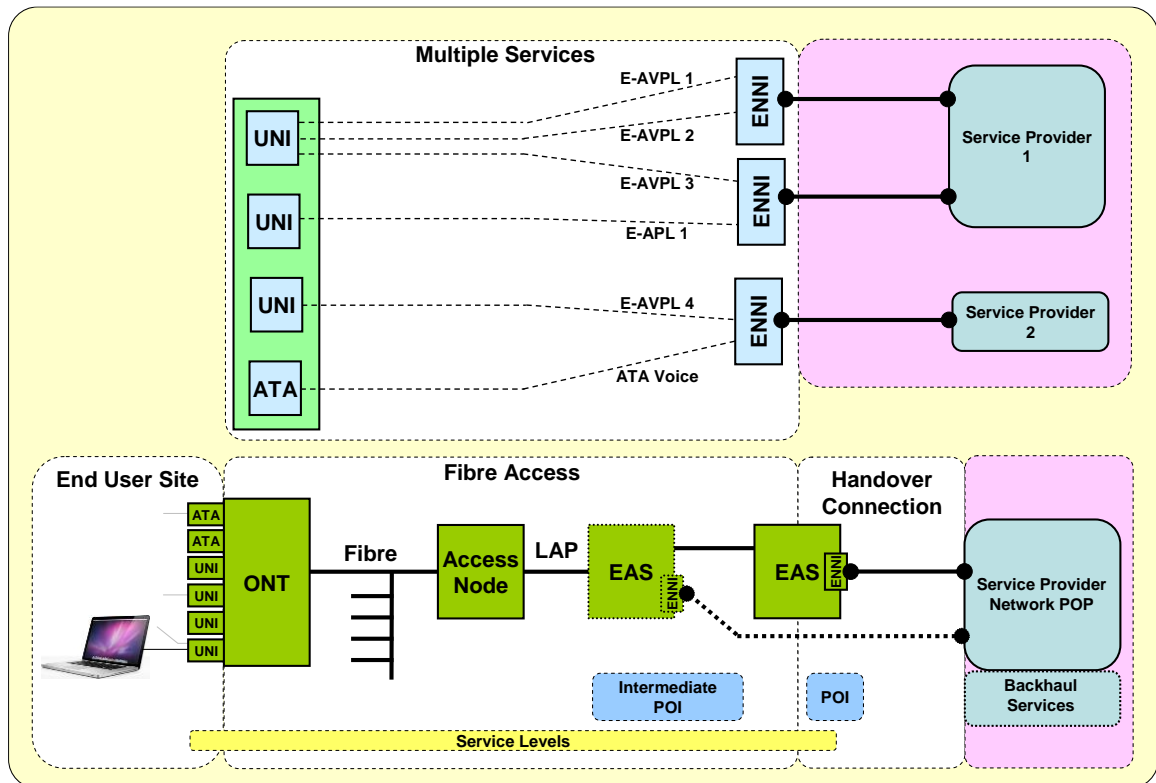

This is a generic diagram showing the standard configuration and service demarcation points. It is not intended to represent every situation or detailed physical architecture. The following points should be noted:

- The Bitstream 3b service and pricing applies from the UNI to the E-NNI at the POI, i.e. there is no incremental charge from the Intermediate POI to the POI.
- Some Bitstream Services will have a single tier of aggregation, i.e. there is no Intermediate POI.
- Where there are multiple tiers of aggregation, the Service Provider can pick the service up at an Intermediate POI. This intermediate POI will service a limited Coverage Area.
- Service Levels (availability, network performance) only apply to UNI to the E-NNI at the POI.
- Access node and aggregation interconnection may use redundant links to meet Service Level requirements.

The Bitstream Services support simultaneous delivery of multiple Service Templates from the same or multiple service providers as follows:

- Multiple E-AVPLs can be delivered to the same UNI.
- An E-APL service requires a dedicated UNI.
- An ATA Voice Service can be considered an E-AVPL with an ATA Voice port at the End User interface. The class and bandwidth characteristics of this E-AVPL are optimised for voice.
- All services delivered to a UNI must belong to the same Service Provider but can be mapped to the same or different E-NNIs.
- The initial Bitstream 3b Service Template contains a single E-APL with 12 bandwidth options and one ATA Voice Service.

## Appendix B – Technical Specification

Technical Specification	
Ethernet	<ul style="list-style-type: none"> <li>• IEEE 802.3 – 2005.</li> <li>• 802.1q supporting 4050VLANs.</li> </ul>
UNI	<p>ONT supports:</p> <ul style="list-style-type: none"> <li>• 4 x UNI; and</li> <li>• 2 x ATA Voice ports.</li> <li>• Optional additional ports:               <ul style="list-style-type: none"> <li>○ RF Overlay port; and</li> <li>○ WiFi.</li> </ul> </li> </ul> <p>Per UNI:</p> <ul style="list-style-type: none"> <li>• 100/1000Base-T.</li> </ul>
UFB Handover Connection (E-NNI)	<p>Ethernet:</p> <ul style="list-style-type: none"> <li>• 802.1ad VLAN (SVID, CVID); or</li> <li>• Double tagged QnQ.</li> </ul>
VLAN	<p>Point-to-Point (E-APL).</p> <p>MTU 2000 Bytes:</p> <p>Unicast Frame Delivery = passed within service CIR/EIR.</p> <p>Multicast Frame Delivery = passed within service CIR/EIR.</p> <p>Broadcast Frame Delivery = passed within service CIR/EIR.</p> <p>Layer 2 Control Protocols Processing = initially none (but may be amended by the LFC from time to time).</p>
Fibre	<p>External fibre must comply with ITU-T specification G.652D.</p> <p>Internal building fibres may comply with ITU-T G.657A. but must meet appropriate fire regulations.</p> <p>Fibre terminations must be SC/APC type connectors (complying with the IEC 61754-4 standard) or as an alternative LC/APC type connectors (complying with the IEC 61754-20 standard) as appropriate.</p> <p>Laser types and path characteristics expected to be designed to a minimum standard which are contained in the documents IEEE 802.3 Section 5 standard OR distance specifications as per the ITU-T G.984 (GPON) standard as appropriate.</p> <p>Testing for power loss will be at either 1310 or 1550 nm 1625 nm reserved for non disruptive testing.</p>