



Enable Networks UFB Services Agreement
Service Description for Bitstream 3a to an NBAP

Version 1.1 Feb 2019

1 Interpretation

- 1.1 The Bitstream 3a Service described in this Service Description will be available from the date it is launched by the LFC. The LFC will notify the Service Provider of the launch date for the Bitstream 3a Service.
- 1.2 References to clauses or sections are references to clauses or sections in this Service Description unless expressly provided otherwise. The definitions set out in the General Terms and the Operations Manual apply to this Service Description unless expressly provided otherwise.
- 1.3 References to the Operations Manual are references to the operations manual for the Bitstream Services.
- 1.4 References to Bitstream 3a in this Service Description are for Bitstream 3a Services delivered to an NBAP location. NBAP locations is further clarified in section 9.

2 The Bitstream 3a Service

- 2.1 The Bitstream 3a Service is a multi-class Bitstream Service suitable for complex business grade applications and premium residential products delivered over a shared fibre access to an NBAP. Bitstream 3a is part of the UFB family of Bitstream Services:

Bitstream 2	Based on the TCF Mass Market service.
Bitstream 3	Based on the TCF Business service.
Bitstream 3a	Based on the TCF Business service with Low Priority options.
Bitstream 4	Based on the TCF Business Premium service.
UFB Handover Connection	Based on the TCF E-NNI specification.
Multicast	Based on the TCF Ethernet Multicast Access (EMA) service.
ATA Voice	An analogue telephone access service.

- 2.2 A diagram of the configuration for the Bitstream 3a Service is set out in Appendix A. The Bitstream 3a Service provides an Ethernet E-APL Bitstream Service from the UNI at the NBAP location to the UFB Handover Connection Service located at the POI that enables a Service Provider to access and interconnect with the LFC Network.
- 2.3 The Bitstream 3a Service is an input service which a Service Provider can combine with other LFC services (or with the Service Provider's own network or wholesale services provided by other service providers) to provide fibre based telecommunications services to NBAP locations.
- 2.4 The Bitstream 3a Service has the following key characteristics:
- 2.4.1 The Bitstream 3a Service includes an Ethernet Bitstream Service that allows up to 4050 VLANs to be passed transparently from the NBAP to the Service Provider, delivered over GPON (shared) fibre.
 - 2.4.2 Support for two classes of traffic, High Priority and Low Priority.
 - 2.4.3 A range of Service Template package offers. A single Service Template is initially offered consisting of a single Ethernet E- APL Bitstream with a range of bandwidth options and a single instance of the ATA Voice Service, with the option to create modified or new Service Templates using 'core building blocks' and the Product Development Process.
 - 2.4.4 Supports tagged or untagged traffic by the End User at the UNI.

- 2.4.5 Complies with the Business service specified in the Telecommunications Carriers Forum's Ethernet Access Service Description v24, 19 January 2011.

3 Bitstream 3a Service and implementation activities

Installation Services

- 3.1 The Bitstream 3a Service includes a Standard Install as set out below (in each case to the extent that the relevant provisioning works are not already complete for the relevant Service Order).¹

Provisioning at NBAP Locations

- 3.1.1 Provisioning of Bitstream 3a Services is not subject to a standard install and is charged as an ancillary service.
- 3.1.2 The installation may include approved conduit or open trenches arranged by the Service Provider or other third parties.
- 3.1.3 A Standard Install for the Bitstream 3a Service to an NBAP location includes:
- (a) a Fibre Lead-in from the Fibre Access Point to an ETP at the closest convenient point at the NBAP, as agreed with the Service Provider, and
 - (b) an extension of the Fibre Lead-in from the ETP (there will not necessarily be a break in the Fibre Lead-in at the ETP) to:
 - (i) a suitable mounted SC/APC connector at a secure location inside the NBAP; or
 - (ii) if there is an OFDF beyond the ETP, a splice or LCA connector on the OFDF.

NBAP Location Termination Point

- 3.1.4 The termination point of the Layer 1 component of the Bitstream 3a Service for the purposes of the Connection at the NBAP location, and the network demarcation point between the LFC Network and the NBAP wiring is, as applicable, either:
- (a) the SC/APC connector on the end of the Fibre Lead-in from the ETP (which is the connector); or
 - (b) if there is an OFDF beyond the ETP, a splice or LCA connector on the OFDF, provided that any ONT installed by the LFC as part of the Bitstream 3a Service will also be part of the LFC Network.
- 3.1.5 The termination point of the Layer 2 component of the Bitstream 3a Service is the 100/1000Base-T UNI on the ONT.

Installation of ONT

- 3.1.6 A Standard Install for the Bitstream 3a Service includes installation of an ONT including:
- (a) supply and fixing of the ONT to the structure of the NBAP location ;
 - (b) supply and connection of fibre pigtail up to 1m long between the Fibre Lead-in termination point and the ONT if required; and
 - (c) testing from the UNI port of the ONT to ensure the Bitstream 3a Service is within the technical specification set out in Appendix B.

¹ Install parameters may differ between LFCs.

- 3.1.7 The Service Provider must ensure a suitably located mains power outlet for the ONT power supply which is not provided as part of a Standard Installation.
- 3.1.8 The LFC will not provide space and power at any NBAP location for the ONT. The location of the ONT must be a suitable environment for electronic equipment being generally a dry, clean indoor area with adequate ventilation.

Testing

- 3.2 The LFC will test the Fibre Lead-in from the termination point at the NBAP location referred to in clause 3.1.3 to the Central Office where the access node is located to ensure the fibre is within the technical specification for fibre set out in Appendix B.

Additional Services

- 3.3 If the Service Provider requires additional services such as:
 - 3.3.1 installation of Fibre-Lead-in diversity at an NBAP location (from the FAP to the ETP or OFDF as applicable);
 - 3.3.2 provision of diversity to an NBAP location (when the second or subsequent instance of the Bitstream 3a Service is purchased);
 - 3.3.3 Premises wiring services; or
 - 3.3.4 installation and testing of Service Provider equipment and services,
 then the LFC may be able to provide the services on request, subject to terms to be agreed between the LFC and the Service Provider.

Core Bitstream 3a Service

- 3.4 The core Bitstream Services provided as part of the Bitstream 3a Service are as follows:
 - 3.4.1 An Ethernet E-APL Service that supports transparent pass-through of 802.1Q frames on a designated UNI on the ONT at the NBAP location.
 - 3.4.2 Delivered over a single 802.1ad SVLAN on the E-NNI at the POI.
 - 3.4.3 Tagged Traffic is treated as follows:
 - (a) Untagged traffic sent from the Service Provider equipment is tagged and treated as Low Priority.
 - (b) Traffic tagged with PCP = 0 will be treated as Low Priority.
 - (c) Traffic tagged with PCP = 1, 2, 3, 4, 5, 6 or 7 will be treated as High Priority.
 - (d) Traffic will be treated as follows based on the individual frames priority:

Type	Ingress	Transport
Low Priority	CIR > 0. EIR = Access Rate – \sum CIR. EIR + CIR policed at ingress.	EIR Queued and Weighted fairly under congestion conditions.
High Priority	CIR policed at ingress. EIR = 0.	Prioritised.

Low Priority traffic can burst up to the Access Rate.

- 3.4.4 One initial Service Template is available consisting of one ATA Voice service and one Ethernet Bitstream Service, using the following parameters:
 - (a) access rate;
 - (b) High Priority service bandwidth; and
 - (c) Low Priority service bandwidth,

as set out in the table below, and can be modified or combined with other services using the Product Development Process as described in clause 3.7.

Access Rate	100/100 Mbps		
Service Bandwidth	High Priority (Symmetric)	Low Priority CIR (Symmetric)	Low Priority EIR (Symmetric)
2.5 Mbps	2.5 Mbps	2.5 Mbps	95 Mbps
5 Mbps	2.5 Mbps	2.5 Mbps	92.5 Mbps
7.5 Mbps	2.5 Mbps	2.5 Mbps	90 Mbps
10 Mbps	2.5 Mbps	2.5 Mbps	87.5 Mbps
20 Mbps	2.5 Mbps	2.5 Mbps	77.5 Mbps
30 Mbps	2.5 Mbps	2.5 Mbps	67.5 Mbps
40 Mbps	2.5 Mbps	2.5 Mbps	57.5 Mbps
50 Mbps	2.5 Mbps	2.5 Mbps	47.5 Mbps
60 Mbps	2.5 Mbps	2.5 Mbps	37.5 Mbps
70 Mbps	2.5 Mbps	2.5 Mbps	27.5 Mbps
80 Mbps	2.5 Mbps	2.5 Mbps	17.5 Mbps
90 Mbps	2.5 Mbps	2.5 Mbps	7.5 Mbps

3.4.5 The Bitstream 3a Service has similar characteristics to the other services within the UFB family of Bitstream Services as identified below:

Attribute	Bitstream 2	Bitstream 3	Bitstream 3a	Bitstream 4
Bitstream	E-AVPL	E-APL	E-APL	E-APL
High Priority	Yes	Yes	Yes	Yes
Low Priority	Yes	No	Yes	No
Service Bandwidths*	From 30/10 Mbps up to 100/50 Mbps	From 2.5Mbps up and downstream to 100/100 Mbps	100/100 Mbps with High Priority from 2.5Mbps	From 100 Mbps up to 10 GigE
MTU	2000 Bytes	2000 Bytes	2000 Bytes	9100
MAC addresses	16	64	64	128
Number of available UNIs	4 standard	4 standard	4 standard	1 with a second UNI available on request
L2CP support	No	No	No	Limited
Diversity	On request with limited availability	On request with limited availability	On request with limited availability	Available to Priority Users in selected areas

* Bandwidth options for each Bitstream Service are detailed in each Bitstream Service Description and further options can be developed using the Product Development Process.

3.4.6 The standard ONT for the Bitstream 3a Service supports four 100Ethernet UNIs and two ATA Voice ports. Additional configurations are available on request.

UNI – NNI characteristics

3.4.7 The Bitstream 3a Service requires a dedicated UNI. Additional UNIs can be used for additional instances of the Bitstream 2 Service or Bitstream 3a Service.

- 3.4.8 The sum of High and Low Priority traffic profiles of all services delivered at a UFB Handover Connection Service can exceed the UFB Handover Connection Service line rate. If there is insufficient line rate to deliver the traffic then frames will be randomly discarded, based on their Class of Service precedence, and Service Levels for that Class of Service do not apply. It is therefore the Service Provider's responsibility to shape and queue traffic appropriately.

New Service Template Options

- 3.5 A Service Provider may request that the LFC creates additional Service Templates as follows:
- 3.5.1 Additional Service Templates can be created using combinations of one more of the following set of standard building blocks:
- (a) Point-to-Point single VLAN Ethernet Bitstream Service (E-AVPL) service using High Priority and Low Priority combinations as set out in the service description for the Bitstream 2 Service. Multiple E-AVPLs can be configured on the same or on different UNIs;
 - (b) Point to Point VLAN (E-APL) service using High Priority combinations as set out in the Service Description for the Bitstream 3 Service;
 - (c) Point to Point VLAN (E-APL) service using High Priority and Low Priority combinations as set out in the Service Description for the Bitstream 3a Service;
 - (d) Multicast VLAN Ethernet Bitstream Service (EMA) using High Priority (CIR) only;
 - (e) ATA Voice port;
 - (f) UNI (100/1000 Base-T) port;
 - (g) WiFi; and
 - (h) Other services or attributes requested by the Service Provider and agreed by the LFC.
- 3.5.2 Ethernet Bitstream Services consisting of High Priority and Low Priority traffic combinations can be created using the following standard building blocks:
- (a) High Priority in increments of 2.5 Mbps upstream and/or downstream;
 - (b) Access Rate in increments of 10 Mbps upstream and/or downstream; and
- 3.5.3 Low Priority CIR in increments of 2.5 Mbps upstream and/or downstream.
- 3.6 Service Templates can be added incrementally to an existing service offer, or supplied as a stand-alone package.
- 3.6.1 Stand alone packages must include Baseband. Stand alone packages mean that the End User connection does not need to consume any other Service Templates in order for services to be provided.
- 3.6.2 Incremental packages can be added as an additional service to an NBAP location already consuming one or more Service Templates.
- 3.7 Requests for additional Service Templates will be implemented and delivered through the Product Development Process. The Product Development Process includes determination of pricing, development, testing and implementation.
- 3.8 The LFC will comply with the Service Provider's request under clause 3.5 in a timely manner. In the event that demand for new Service Templates exceeds the LFC's capacity to deliver the new Service Templates then the LFC may prioritise the Service Template requests in accordance with the Operations Manual.

Operations, Administration and Maintenance

- 3.9 The Bitstream 3a Service will support Service Provider remote access to the ONT via a service management gateway for appropriate management. A Service Provider may request particular management attributes via the Product Development Process.
- 3.10 The Bitstream 3a Service will support Ethernet Service Operations and Maintenance (**OAM**) for service integrity testing, fault diagnostics and performance measurement using ITU Y.1731. OAM capability will be phased in as the functionality is developed and deployed in scale and may be updated or amended by the LFC from time to time.

Service Requirements

- 3.11 To use the Bitstream 3a Service the Service Provider must have the capability to access and interconnect with it, by one of the following:
 - 3.11.1 Co-locating Service Provider equipment at the POI using the UFB Handover Connection Service and Central Office and POI Co-location Service;
 - 3.11.2 Connecting to third party co-location space at the POI using the UFB Handover Connection Service, and with the third party taking the Central Office and POI Co-location Service;
 - 3.11.3 Connecting to a backhaul service at the POI; or
 - 3.11.4 By using the Direct Fibre Access Service to connect to Service Provider equipment at a remote location within the Central Office area.

Additional Service Characteristics

- 3.12 The technical specification of the Bitstream 3a Service is set out in Appendix B.
- 3.13 The LFC will provide certain support and other assistance as part of the Bitstream 3a Service including:
 - 3.13.1 An electronic facility for Service Requests;
 - 3.13.2 An electronic facility for fault notifications; and
 - 3.13.3 A tool to assist the Service Provider in determining the location and availability of the Bitstream 3a Service (pre-qualification),
 each as more particularly set out in the Operations Manual.
- 3.14 The Bitstream 3a Service specifically excludes:
 - 3.14.1 The UFB Handover Connection Service;
 - 3.14.2 Provision or maintenance of any cabling or connection or active device:
 - (a) beyond the service demarcation points described in clauses 4.1 and clause 5.1;
 - (b) between the jack terminating the LFC provided Fibre Lead-in and the ONT where that cabling or connection is not provided by the LFC and the LFC has not agreed to take responsibility for that cabling or connection.
 - 3.14.3 Configuration, monitoring, operation, on-going support or maintenance of Service Providers' applications, equipment or networks; and
 - 3.14.4 Supply of AC mains & UPS power, accommodation space, heating, ventilating, and air conditioning and facilities at the NBAP location.

4 Service Demarcation Point at NBAP Location

- 4.1 The service demarcation point at the NBAP location is the 100/1000Base-T UNI on the ONT.
- 4.2 The Bitstream 3a Service excludes the NBAP location wiring. If a fault reported by the Service Provider is found to be caused by the NBAP equipment (CPE) or the wiring at the NBAP location beyond the service demarcation point, then the Service Provider may be charged the no fault found

fee in the Price List. Note the wiring should comply with the industry standard Premises wiring requirements which are available at www.tcf.org.nz.

5 Service Demarcation Point at POI

- 5.1 The Bitstream 3a Service is delivered as a transparent VLAN (the logical service demarcation point) on the UFB Handover Connection located at the POI.
- 5.2 The physical service demarcation point is the MOFDF in the POI, which is part of the UFB Handover Connection Service.
- 5.3 The UFB Handover Connection Service is a separate service and is a prerequisite to the supply of the Bitstream 3a Service i.e. Service Provider's must first purchase and then continue to maintain a UFB Handover Connection Service at all times while taking the Bitstream 3a Service.

6 LFC and Service Provider Responsibilities

- 6.1 Other LFC and Service Provider responsibilities are detailed in the General Terms and the Operations Manual.

7 Fibre Diversity

- 7.1 The Bitstream 3a Service provides a single fibre between the Central Office and the NBAP location.
- 7.2 Diversity (a second or subsequent instance of the Bitstream 3a Service between the Fibre Access Point and the Central Office) will be available as an option for some but not all NBAP locations. Standard Installation Service Levels do not apply to the provision of the diverse products and each instance will be treated as an individual line for the purpose of availability Service Levels.
- 7.3 Where available, the diverse optical paths will be in separate fibre cable sheaths, and if requested in separate cable routes. The diverse cable routes will be a minimum of the width of a street apart, and should not share any manholes or access points. Separate entries into the Central Office will also be used where available.
- 7.4 The Service Provider can also request diverse access to NBAP locations, or access to diverse Central Offices as part of a Non-Standard Install, however this will not be available in all cases.
- 7.5 There may be practical limitations to providing full physical diversity to some sites. The provision of a separate entry to an LFC Central Office will have unique site specific engineering considerations and may attract additional costs.

8 Bitstream 3a Service Levels

- 8.1 Service Levels for both the Layer 1 and Layer 2 components of the Bitstream 3a Service are set out in the Service Level Terms for the Bitstream Services.

9 NBAP Location Clarification

- 9.1 Non Building Access Points (NBAPs) require a unique address or NBAP location to be created and network records to be allocated. They are generally not consumed by an End User at a Premises.
- 9.2 **NBAP types will take various forms with the following list setting out the initial service products which can be added to over time or deleted as allowed for by the WSA:**
 - 9.2.1 **WiFi Sites**
 - 9.2.2 **Traffic Control (Lights/Cameras/Signs)**
 - 9.2.3 **Security Cameras**
 - 9.2.4 **Mobile Cellular Sites**

- 9.2.5 ATMs
- 9.2.6 Lift Phones
- 9.2.7 Phoneboxes
- 9.2.8 Pump Stations
- 9.2.9 Billboards

9.3 Appendix A – Diagram

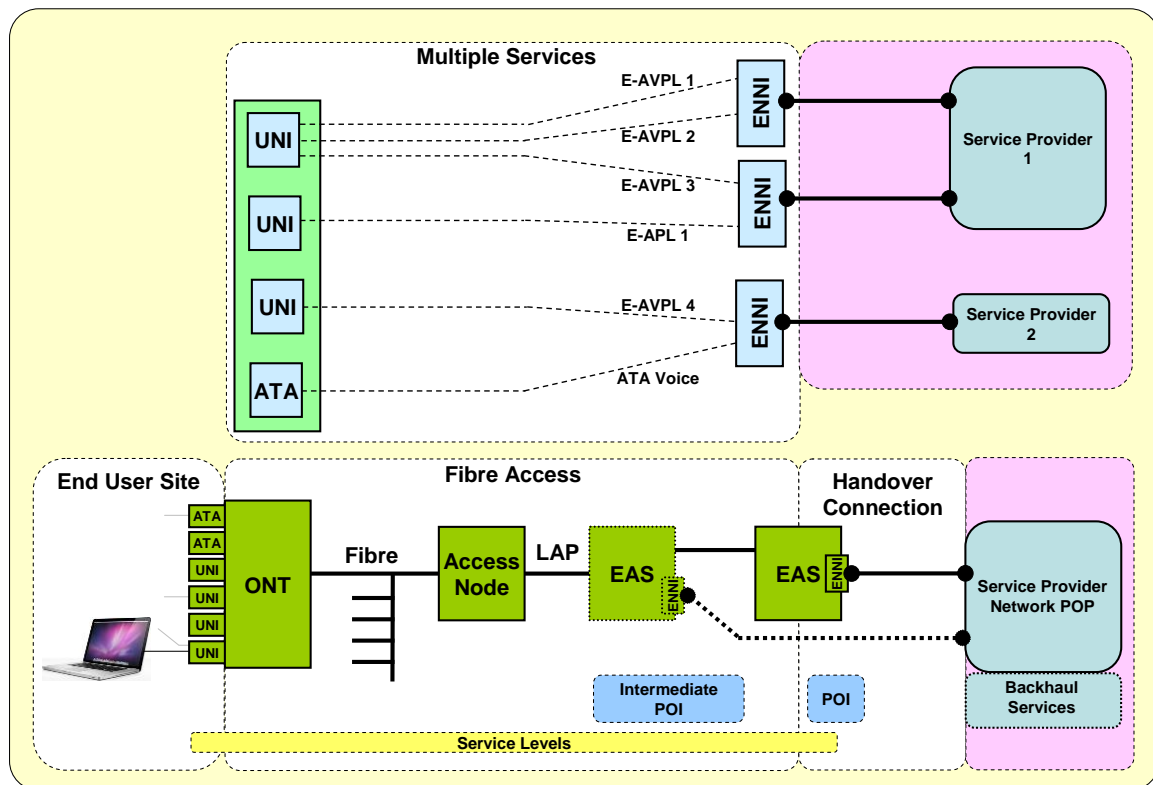

This is a generic diagram showing the standard configuration and service demarcation points. It is not intended to represent every situation or detailed physical architecture. The following points should be noted:

- The Bitstream 3a service and pricing applies from the UNI to the E-NNI at the POI, i.e. there is no incremental charge from the Intermediate POI to the POI.
- Some Bitstream Services will have a single tier of aggregation, i.e. there is no Intermediate POI.
- Where there are multiple tiers of aggregation, the Service Provider can pick the service up at an Intermediate POI. This intermediate POI will service a limited Coverage Area.
- Service Levels (availability, network performance) only apply to UNI to the E-NNI at the POI.
- Access node and aggregation interconnection may use redundant links to meet Service Level requirements.

The Bitstream Services support simultaneous delivery of multiple Service Templates from the same or multiple service providers as follows:

- Multiple E-AVPLs can be delivered to the same UNI.
- An E-APL service requires a dedicated UNI.
- An ATA Voice Service can be considered an E-AVPL with an ATA Voice port at the NBAP equipment interface. The class and bandwidth characteristics of this E-AVPL are optimised for voice.
- All services delivered to a UNI must belong to the same Service Provider but can be mapped to the same or different E-NNIs.
- The initial Bitstream 3a Service Template contains a single E-APL with 12 bandwidth options and one ATA Voice Service.

Appendix B – Technical Specification

Technical Specification	
Ethernet	<ul style="list-style-type: none"> • IEEE 802.3 – 2005. • 802.1q supporting 4050VLANs.
UNI	<p>ONT supports:</p> <ul style="list-style-type: none"> • 4 x UNI; and • 2 x ATA Voice ports. • Optional additional ports: <ul style="list-style-type: none"> ○ RF Overlay port; and ○ WiFi. <p>Per UNI:</p> <ul style="list-style-type: none"> • 100/1000Base-T.
UFB Handover Connection (E-NNI)	<p>Ethernet:</p> <ul style="list-style-type: none"> • 802.1ad VLAN (SVID, CVID); or • Double tagged QnQ.
VLAN	<p>Point-to-Point (E-APL).</p> <p>MTU 2000 Bytes:</p> <p>Unicast Frame Delivery = passed within service CIR/EIR.</p> <p>Multicast Frame Delivery = passed within service CIR/EIR.</p> <p>Broadcast Frame Delivery = passed within service CIR/EIR.</p> <p>Layer 2 Control Protocols Processing = initially none (but may be amended by the LFC from time to time).</p>
Fibre	<p>External fibre must comply with ITU-T specification G.652D.</p> <p>Internal building fibres may comply with ITU-T G.657A. but must meet appropriate fire regulations.</p> <p>Fibre terminations must be SC/APC type connectors (complying with the IEC 61754-4 standard) or as an alternative LC/APC type connectors (complying with the IEC 61754-20 standard) as appropriate.</p> <p>Laser types and path characteristics expected to be designed to a minimum standard which are contained in the documents IEEE 802.3 Section 5 standard OR distance specifications as per the ITU-T G.984 (GPON) standard as appropriate.</p> <p>Testing for power loss will be at either 1310 or 1550 nm 1625 nm reserved for non disruptive testing.</p>